



WORKING FOR A HEALTHY FUTURE

Strategic Consulting: 538-0000
March, 2012

GUIDANCE FOR COLLECTION OF INHALABLE AND RESPIRABLE NI DUST

Araceli Sánchez Jiménez, Martie van Tongeren, Robert J
Aitken

RESEARCH CONSULTING SERVICES

Multi-disciplinary specialists in Occupational and Environmental Health and Hygiene

www.iom-world.org

OUR IMPACT ON THE ENVIRONMENT

At IOM we seek to minimise our environmental impact. We produce thousands of reports every year and these consume a large quantity of paper. To minimise our impact on the environment, we prefer to only provide an electronic copy of reports, although we can provide a paper copy on request. If you have any additional requirements please let us know.

CONTENTS

OUR IMPACT ON THE ENVIRONMENT	2
ABBREVIATIONS AND DEFINITIONS	<u>43</u>
EXECUTIVE SUMMARY	<u>53</u>
1 BACKGROUND AND SCOPE	<u>63</u>
2 INTRODUCTION TO AEROSOL SAMPLING	<u>73</u>
2.1 PERSONAL INHALABLE DUST SAMPLERS	<u>83</u>
2.2 PERSONAL RESPIRABLE DUST SAMPLERS	<u>103</u>
2.3 MULTI-FRACTION samplers	<u>153</u>
3 REFERENCE GUIDANCE SOURCES ON INHALABLE AND RESPIRABLE SAMPLING	<u>193</u>
4 SAMPLING STRATEGY	<u>213</u>
5 DISCUSSION AND RECOMMENDATIONS	<u>233</u>
6 REPORT AUTHOR AND APPROVER'S SIGNATURE	<u>263</u>
7 REFERENCES	<u>273</u>
APPENDIX 1 NIOSH METHOD 0600 PARTICULATES NOT OTHERWISE REGULATED, RESPIRABLE	<u>303</u>
APPENDIX 2 MDHS 14/3 GENERAL METHODS FOR SAMPLING AND GRAVIMETRIC ANALYSIS OF RESPIRABLE AND INHALABLE DUST	<u>303</u>
APPENDIX 3 ECHA INDICATIVE NUMBER OF MEASUREMENTS NEEDED	<u>313</u>

ABBREVIATIONS AND DEFINITIONS

CIP	Capteur Individuel de Poussiere
CIS	Conical Inhalable Sampler
Dae	The aerodynamic diameter is the diameter of a sphere of density 1000 kg m ⁻³ with the same settling velocity as the particle of interest
DNEL	Derived non-effect level
DMEL	Derived minimum-effect level
DO	Dorr Oliver
GF	Glass Fibre
GSD	Geometric Standard Deviation
GSP	Gesamtstaubprobenahme an der Person
HD	Higgins Dewell
IOM	Institute of Occupational Medicine
LOD	Limit of Detection
MMAD	Mass Median Aerodynamic Diameter
OEL	Occupational Exposure Limit
PSD	Particle Size Distribution
PUF	Polyurethane Foam
REACH	Registration, Evaluation, Authorisation and restriction of Chemicals
RCR	Risk Characterization Ratio
SCOEL	Scientific Committee on Occupational Exposure Limits
SEGs	Similarly Exposed Groups
WASP	Workplace Analysis Scheme for Proficiency

EXECUTIVE SUMMARY

An evaluation of currently commercially available gravimetric dust samplers was performed to select suitable candidate samplers for measuring personal respirable and inhalable Nickel (Ni) dust exposure. This involved a literature review on the performance of the different samplers. The selection was based on the following requirements:

- the samplers should follow the recognised ACGIH/CEN/ISO criteria for collection of inhalable and respirable airborne particles;
- evidence of agreement of the sampler performance with these criteria should be available in the peer-reviewed literature;
- the sampling medium should not impede the chemical analysis of Ni and Ni compounds; and
- the samplers should be readily commercially available worldwide.

The IOM Inhalable Dust sampling head is widely recognised as a sampler that closely follows the inhalability criteria, although it is acknowledged that the sampling efficiency deviates with low ($< 0.5 \text{ m s}^{-1}$) and high wind ($> 4 \text{ m s}^{-1}$) velocities and with increasing particle size (Kenny et al. 1997a, Sleet and Vincent, 2011). The sampler is easy to assemble, not expensive, and it is used worldwide.

The respirable fraction of airborne dust is most commonly sampled using cyclones. The two main cyclones, the Higgins Dewell (HD) and Dorr Oliver (DO) cyclone have been reported to have similar performance. The former is most widely used in the EU, whereas the DO cyclone is more common in the US. The advantage of the HD cyclone is that cassettes are re-usable, resulting in lower costs.

Multi-fraction samplers offer the advantage of sampling both respirable and inhalable fractions simultaneously. However, the performance of these samplers has been studied less than single fraction samplers such as the IOM sampling head and the cyclones. The Conical Inhalable Sampler (CIS) and IOM dual samplers are multi-fraction samplers that use polyurethane foam (PUF) as the separating medium. Foams have higher gravimetric instability than filters, may contain relatively high and variable levels of Ni, and the use of a filter plus foam to derive the inhalable fraction results in higher LODs. The 3-stage impactor Respicon offers an easy alternative for collection of the three health-relevant fractions: inhalable, thoracic and respirable. However, the sampler is relatively expensive (€1,091) compared to the other samplers and its performance in terms of particle separation is sensitive to variations in the flow-rate.

In summary, the IOM and cyclone heads are well recognised for following the ACGIH/ISO/CEN curves for inhalable and respirable dust, respectively. Both samplers have been widely studied and their sampling efficiencies are well characterized. The IOM and CIS dual samplers and the Respicon offer the advantage of sampling simultaneously both particle size fractions, allowing direct estimation of the respirable amount of Ni contained in the inhalable fraction. However, fewer studies have assessed the performance of these multi-fraction samplers and therefore their biases are less well characterised. Therefore, it is recommended to use the IOM Inhalable sampling head for inhalable dust and a Higgins-Dewell or Dorr Oliver cyclone for respirable dust.

1 BACKGROUND AND SCOPE

The REACH Nickel consortia plan to update the site-specific guidance for sampling of airborne Ni dust by the first quarter of 2012, including a recommendation on the methodology for measuring personal Ni exposure in the inhalable and respirable size fractions. The Scientific Committee on Occupational Exposure Limits (SCOEL) has recently issued a recommendation for two indicative occupational exposure limits (OELs), one for all Ni compounds (excluding metal) as an inhalable aerosols ($0.01 \text{ mg Ni m}^{-3}$) and one for nickel metal and nickel compounds ($0.005 \text{ mg Ni m}^{-3}$) as respirable aerosol (SCOEL, 2011).

The Institute of Occupational Medicine (IOM) (Edinburgh, UK) was contracted by the Nickel Institute to review commercially available sampling devices and prepare a short report describing the most suitable sampling devices to assess exposure to inhalable and respirable Ni.

This document describes and reviews appropriate personal gravimetric sampling methods for collection of personal inhalable and respirable dust.

The ideal sampling device should fulfil the following criteria:

- the samplers should be designed to follow the ACGIH/ISO/CEN definitions for collection of inhalable and respirable airborne particles;
- evidence of agreement of the sampler performance with these criteria should be available in the peer-reviewed literature;
- the sampling medium used with the sampling devices should not impede the chemical analysis of Ni; and Ni compounds; and
- the samplers should be readily commercially available worldwide.

2 INTRODUCTION TO AEROSOL SAMPLING

The probability of airborne particles to deposit in different regions of the human respiratory tract depends mostly on their aerodynamic diameter (D_{ae}). Therefore, health related aerosol size fractions have been defined in order to understand the potential health effects of exposure to airborne particles. Three penetration curves have been defined that link the probability of aerosol penetration to D_{ae} of airborne particles (Figure 1) (CEN, 1992; ISO, 1995; ACGIH, 1995).

- 1) The inhalable fraction is the mass fraction of total airborne particles that can penetrate the nose and mouth. The target specification for sampling the inhalable fraction is given in EN481 (CEN, 1993) and has 100% penetration efficiency for small particles, dropping to 50% for 100 μm particles. The inhalable fraction is not defined beyond 100 μm .
- 2) The thoracic fraction is the fraction of inhalable particles that can penetrate the bronchial region and is described by a cumulative log-normal distribution with a median of 11.64 μm and a geometric standard deviation (GSD) of 1.5.
- 3) The respirable fraction is the fraction of inhalable particles that reach the alveolar region of the lung and is described by a cumulative log-normal distribution with a median of 4.25 μm and a GSD of 1.5.

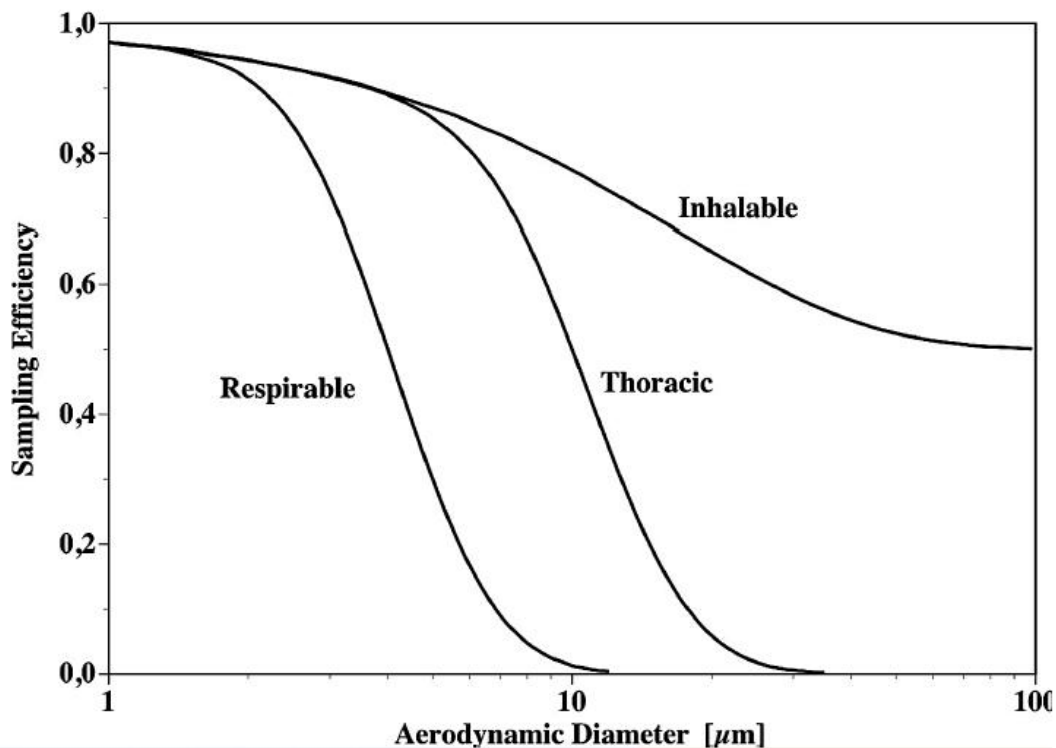

Figure 1 The ISO/CEN/ACGIH sampling conventions for the inhalable, the thoracic, and the respirable aerosol fractions (source: Lidén and Harper, 2007)

Personal sampling devices have been designed to mimic these penetration curves. For example, the Institute of Occupational Medicine (IOM), and the conical inhalable

sampler (CIS) (also known as GSP) were designed for measuring inhalable dust, while cyclone type samplers have been designed for the collection of the respirable fraction (Vincent, 2007). Other samplers have been developed that collect multiple fractions simultaneously, such as cascade impactors, or samplers that use foams to separate the inhalable and respirable fraction, for example the CIS and IOM dual-fraction samplers.

The collected particles can be analysed using conventional methods: gravimetric weighing, chemical analysis or microscopic observation. The mass of the particles is determined by weighing the filters before and after sampling.

The performance of these samplers have been investigated in numerous studies in workplaces and under controlled conditions in laboratory simulations (e.g. Vaughan et al. 1990; Vincent, 1995; Vinzents et al. 1995; Aitken and Donaldson, 1996; Tsai et al. 1996a, 1996b; Wilsey et al. 1996; Kenny et al. 1997a; Kenny et al. 1999; Ogden et al. 1997; Demange et al. 2002; Lidén et al. 2000; Görner et al. 2001; Görner et al. 2010; Teikari et al. 2003). Most agreed that different samplers can report different concentration levels in some circumstances. The following factors have been reported to affect the sampler performance:

- environment: air velocity and direction;
- sampler: inlet size, geometry, orientation, the sampler conductive properties;
- aerosols: particle size, electrical charge, particle bounce properties.

Therefore, the use of different sampling devices causes a degree of uncertainty when using the sampling results to check compliance with regulatory limits, or when the data are used for risk assessment and management purposes.

2.1 PERSONAL INHALABLE DUST SAMPLERS

The most common personal inhalable samplers for dust are the IOM sampling head, the CIS, the button sampler and the CIP 10 (capteur individuel de poussiere). The IOM sampling head has long been recognised as a reference method for sampling the inhalable fraction as it follows closely the inhalability criteria. The CIS and IOM dual sampler offer the advantage of being able to sample the inhalable and the respirable size fractions simultaneously. Therefore the CIS and IOM sampling heads should be considered when assessing the inhalable concentration.

The CIP 10 sampler is mostly used in France. There are three different versions for the measurement of the inhalable (CIP 10-I), thoracic (CIP 10-T) and respirable (CIP 10-R) fractions. The CIP sampler is relatively expensive (€1,250¹ approximately) and more difficult to assemble compared to the IOM head and the CIS. In addition, Kenny et al. (1997, Görner et al. 2010) found that the sampling efficiency of the CIP 10-I v1 and v2 deviated from the CEN/ISO/ACGIH curve.

The button sampler has been reported to deviate from the inhalability criteria in several studies (Kenny et al. 1997a, Aizenberg et al. 2001, Görner et al. 2010) and it is also relatively expensive (\$249²). Therefore we have not considered the CIP 10-I and button samplers as inhalable-only samplers in this report.

¹ <http://www.arelco.fr/docs/produits/CIP101.pdf>

² <http://www.skcsshopping.com/ProductDetails.asp?ProductCode=225-360>

2.1.1 IOM sampling head

The IOM sampling head is designed to collect inhalable particles (particles with a d_{ae} below 100 μm collected with 50% efficiency) for optimal agreement with the CEN/ISO/ACGIH convention, when operated at $2.0 \text{ l}\cdot\text{min}^{-1}$ (HSE, 2000). The IOM head comprises a cylindrical body, with a reusable cassette and front plate. The cassette incorporates a 25-mm filter. The sampler has a 15-mm circular inlet with a lip that protrudes 1.5-mm outwards (Figure 2). The purpose of the lip is to minimize the potential for particles deposited on the outer surfaces of the inlet to be carried into the sampler.

There are a wide range of filters suitable for sampling with this device and also for the analysis of Ni (e.g. glass fibre, cellulose ester, membrane filters).

There are two versions of the head and cassette, one made of conductive plastic and another of stainless steel. For personal sampling, the plastic head version is preferred as this is lighter and less expensive; however the stainless steel cassettes are less prone to weight changes due to moisture uptake than the plastic cassettes. Thus, stainless steel cassettes are recommended for both IOM configurations, the dual IOM and the IOM inhalable head. Approximate costs are shown in Table 1.

Table 1 Cost of the IOM head (excludes taxes)

Item	SKC (\$)	Casella (£)
IOM plastic head	85	34
IOM metal head	319	78
Plastic cassettes	20	6
Metal cassettes	95	33



Figure 2 IOM conductive plastic (left) and stainless steel (right) sampler
(source: <http://www.skcinc.com/instructions/37372.pdf>)

2.2 PERSONAL RESPIRABLE DUST SAMPLERS

Respirable dust is most commonly sampled using a cyclone. The rapid circulation of air in the cyclone separates particles according to their D_{ae} . Thus, particles larger than the specified size are forced to the periphery of the air stream, falling into a grit pot and are discarded, while particles of the specified size are collected on the filter. The particle size selectivity of the cyclone and its penetration is achieved by design of the cyclone geometry and selection of specific flow-rates. Therefore deviations from the sampler's ideal flow-rate it is likely to result in significant sampling errors.

There are two main cyclone designs, HD and the DO cyclones. Both are recommended by the UK Health and Safety Executive (HSE) (HSE, 2000) and by NIOSH (method 0600) for sampling respirable particles. The HD is mostly used in Europe and the DO is most widely used in the US. Both cyclones are available in conductive plastic and metal. Examples of these types are made by various manufacturers (e.g. Casella, SKC, BGI). The GS-3 has a tangential design which decreases particle losses due to impaction and has been shown to follow closely the respirable curve than the DO cyclone (Trakumas and Hall, 2003).

All HD and DO cyclones are designed to meet the ACGIH/CEN/ISO size-selection curve, with a 50% cut-point of $4.0 \mu\text{m}$ (with bias within ISO/NIOSH requirements). The available literature suggests that there are few differences in the performance of the different cyclone heads available. Therefore, assuming there are no significant deviations from the nominal flow-rate, all cyclones perform well compared to the respirable dust criteria.

The HD cyclone is easier to assemble and the filter cassettes are reusable. The sampler is equipped with an inlet, an outlet, and a stainless steel filter support grid (Figure 3). There are two versions of the HD design, one with the inlet on the top manufactured by Casella and the other one with the inlet on the side manufactured by SKC. SKC manufactures two sizes: a 25-mm cyclone and a 37-mm cyclone. We did not identify any studies that have compared both configurations. However, a common source of error when carrying out personal sampling is due to changes in the flow rate due to bending of the tube that connects the sampler with the pump. In this regard the cyclone with the inlet at the top may be preferred as the tubing is less likely to bend/kink to constrict air-flow.

There is little or no difference in the performance between the 25 and 37 mm cyclone. On the one hand smaller filters will require slightly less extraction solvent and have a slightly higher gravimetric stability than larger filters. On the other hand, at high dust concentrations the 25-mm filter may be more likely to become overloaded compared to the 37-mm filter. The cyclones with the larger filters also have a lower air-flow resistance, and this may reduce the likelihood of deviations from the correct flow rate (HSE, 2000).



Figure 3 Casella Measurement plastic cyclone components (right)

The DO cyclone is used in conjunction with 37 mm 3 piece open face filter cassettes (Figure 4). The sampler is manufactured by Casella, SKC, Zefon and BGI. The sampler is available in Ni aluminium plated, or conductive plastic.

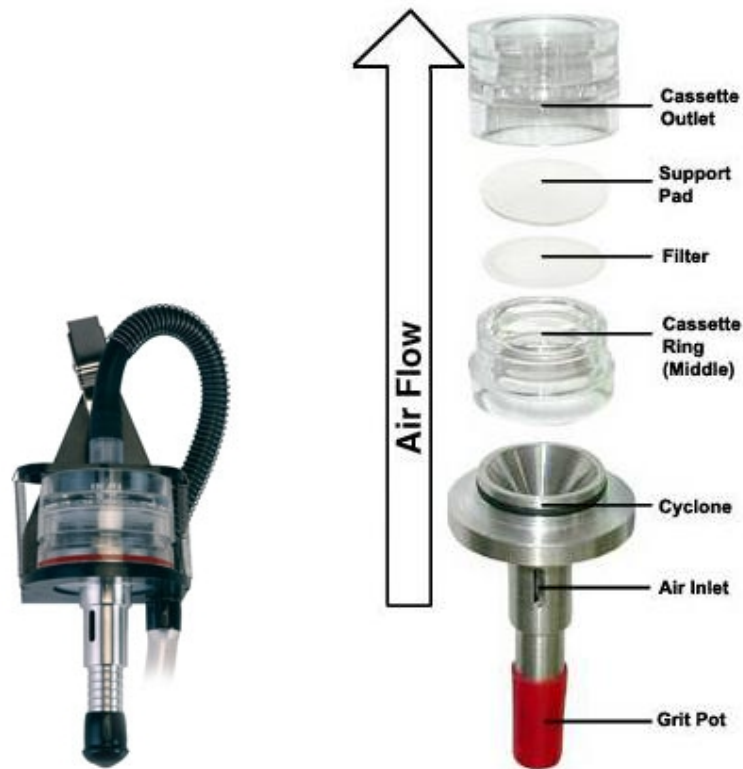

Figure 4 Dorr Oliver cyclone by Casella (right) and exploded view of the Dorr Oliver cyclone manufactured by SKC (left)

The GS-3 has a similar design to the DO cyclone but is made of a 10-mm conductive plastic unit used with a standard three-piece cassette with a filter (Figure 5). The tangential inlet minimizes sampling errors that can occur when particles impact on the wall of the cyclone opposite the inlet. The assembly is slightly more complex than for the conventional DO and HD cyclones. The cyclone can incorporate a 37-mm or 25-mm cassette.

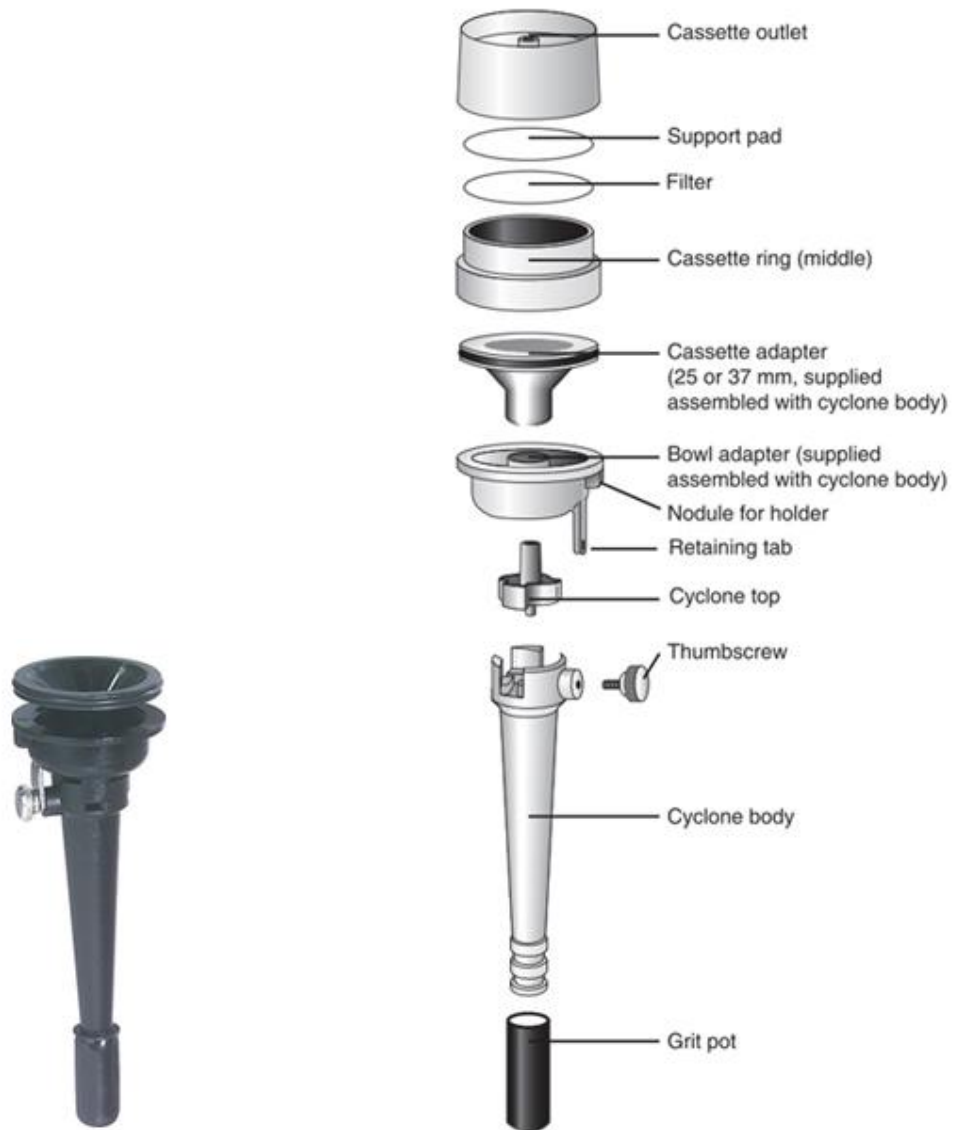

Figure 5 GS-3 cyclone (source: <http://www.skcinc.com>)

Table 2 shows details of the cyclone characteristics, manufactures and costs.

Table 2 Details of commercially available cyclones (prices do not include VAT)

Name	Manufacturer	Flow-rate (l.min ⁻¹)	Weigh (g)	Sampling media	Characteristics	Costs	
						Cyclone	Cassette
Higgins and Dewell	Casella ³	2.2	60	25-mm filters 37-mm filters	Conductive plastic	£25	£25 pkg/5
	SKC ⁴	2.2	60	37-mm filters 25-mm filters	Conductive plastic	\$80 (37-mm) \$88 (25-mm)	\$12 each
Dorr-Oliver	BGI ⁵	2.2	NA	37-mm filters	Conductive plastic (CAS4 model)	\$75	BGI dose not sell cassettes
	Casella	1.7	NA	37-mm filters in 3 piece cassettes	Aluminium	£77	
	Zefon ⁶	2.5	118	37-mm filters in 3 piece cassettes	Aluminium	\$95	
	SKC	2.5	NA	25 or 37-mm filters in 3 piece cassettes	Aluminium	\$80	\$10-12 each
	BGI	2.2	102	37-mm filters in 3 piece cassettes	Nickel plated aluminium (BGI4L model)	\$250	
					Conductive plastic (BGI4CP model)	\$125	BGI dose not sell cassettes
GS-3	SKC	2.75	NA	25 or 37-mm filters in 3 piece cassettes	Conductive plastic	\$80	\$12 pkg/10

NA: not available

³ <http://www.casellameasurement.com>

⁴ <http://www.skinc.com/>

⁵ <http://www.bgiusa.com/>

⁶ <http://www.zefon.com>

2.3 MULTI-FRACTION SAMPLERS

2.3.1 IOM dual fraction sampler

MultiDust PUF discs are available that can be inserted into the standard IOM cassette which transform the IOM into a versatile personal dust sampler, able to sample inhalable and respirable fractions individually or simultaneously (Figure 6). The foams are designed to have a specific porosity such that the penetration characteristics correspond to the respirable fraction. Using this method, respirable particles can be collected on the filter at the back of the cassette. The total sample collected in the cassette, including that collected on the foam, can be weighed with the filter for determination of the inhalable fraction.

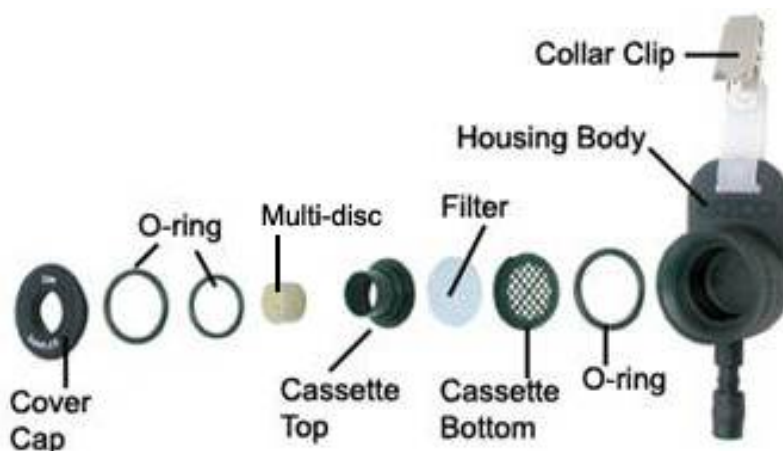

Figure 6 Exploded view of the Institute of Occupational Medicine (IOM) dual sampler

As with other foam based collection samplers (e.g. CIS), variation in the weight stability of the foam has been identified as a potential problem.

2.3.2 Conical inhalable sampler (CIS)

The CIS or GSP sampler is a multi-fraction sampler that simultaneously collects the inhalable and respirable fractions. It comprises a conical inlet with an 8-mm hole at the top (Figure 7). The inlet is connected to a cassette that holds a 37-mm filter and when worn the orifice faces outwards. The CIS sampler uses two PUFs as size selective media. Respirable particles pass through the foams and are collected on the filter (e.g. a glass fibre filter). The sum of the masses collected on the foams and filter provide data on the inhalable fraction.

The sampler operates at a flow-rate of $3.5 \text{ l}\cdot\text{min}^{-1}$. It is manufactured as the Gesamtstaubprobenahme an der Person (GSP) sampler by GmgH and Co. and is also available from Casella and by BGI. The CIS is recommended for sampling the inhalable fraction by HSE (HSE, 2000), although it is acknowledged that under certain conditions the sampler can exhibit biases (Kenny et al. 1997, 1999). There are PUFs also available to sample PM_{10} and $\text{PM}_{2.5}$.

The costs are detailed in Table 3.

Table 3 Cost of the Conical Inhalable Sampler (CIS) (excludes taxes)

Item	Casella (£)
CIS body	27
Cassettes for filter	19
Cassettes for PUF	19
PUF	20



Figure 7 Casella Conical Inhalable sampler

2.3.3 Cascade Impactors

A different approach to the use of PUF for collection of a multisize fraction is cascade impactors (CIs). CIs utilize the inertial characteristics of a particle moving in a gas stream to separate the aerosol into different single fractions. Multi-stage impactors consist of a number of separated plates arranged in parallel with each containing an inlet nozzle, collection plate, and outlet orifice. The number of plates varies according to the models. Some impactors have only two/three plates for collection of the inhalable thoracic and respirable fraction, while other have a greater number of plates which allows estimation of the complete particle size distribution (PSD) of the aerosol. The greater number of filters used for the analysis result in larger costs compared to the IOM head and cyclone. In addition, increasing the number of fractions that will be separated may reduce the overall sensitivity of the methodology and may require longer sampling durations in order to collect detectable levels for each fraction.

Respicon

The Respicon sampler consists of a two-stage virtual impactor which is arranged together with three filters to collect the inhalable, thoracic and respirable fraction according to the ACGIH/ISO/CEN convention. Coarse particles pass straight through to the lower collector while other particles are aerodynamically separated. Particles of smaller diameter follow flow paths and are distributed into the other stages according to

their flow characteristics. The device performs at a flow rate of $3.11 \text{ l}\cdot\text{min}^{-1}$ and uses 37-mm GF or membrane filters.

For the gravimetric analysis the thoracic fraction is the sum of the mass of the first and second filters and the inhalable fraction is the combined mass of the three filters.

The model Respicon TM also measures the mass of particles in real time using a light-scattering technique. However, this is not Ni specific and since there is not a gravimetric sample it is not suitable for specific analysis of Ni.

The Respicon is currently manufactured by Hund Wetzlar (note that since 2008, TSI does not manufacture this device). It weighs 200 g and the cost is €1,091 for the gravimetric version and €6,011 for the Respicon TM.



Figure 8 Respicon TM Respicon and virtual impactor

Marple Cascade Impactor

The Marple Series 290 Personal Cascade Impactor is designed for personal measurements, establishing the aerodynamic PSD from 0.4 to $21 \mu\text{m}$. Samplers come in various configurations - 2-stage, 4-stage, 6-stage and 8-stage. Cut-off points for the 8-stage configuration are $>21 \mu\text{m}$ and above, 15, 10, 6.5, 3.5, 1, 0.7, 0.4 and final filter. The sampler inlet can be modified to place an IOM head so as to extend the particle size cut-off to the inhalable fraction.

The sampler does not provide straightforward data. The gravimetric results obtained from each impactor stage have to be entered into a calculation tool. A relationship between the cumulative particle mass and particle size can be derived from which the inhalable (only for the modified version), thoracic and respirable mass are calculated. Data also allow calculation of the Mass Median Aerodynamic Diameter (MMAD) and

Geometric Standard Deviation (GSD). A full description of the algorithms used for the calculation is provided by Sánchez Jiménez et al. (2010)

Problems associated with the Marple CI include particle bounce, losses on the impaction surface (Vincent, 2007) and lack of clearly defined aspiration efficiency of the sampling inlet (Wu and Vincent, 2007). However, collection substrates loaded into the impactors may be greased to prevent losses due to particle bounce. Creely and Aitken, (2007) reported lower inhalable concentrations with the modified Marple CI compared to the IOM head.

3 REFERENCE GUIDANCE SOURCES ON INHALABLE AND RESPIRABLE SAMPLING

National regulatory organisations and International standards organizations have issued guidance documents for the assessment of the inhalable and respirable particles according to their national regulations. Table 4 shows a list of these guidances. Those freely available have been included in Appendix 1 and 2.

Table 4 Guidance documents for sampling of inhalable and respirable particles

Institution	Standard	Title	Link
ISO	15202-1	Workplace air -- Determination of metals and metalloids in airborne particulate matter by inductively coupled plasma atomic emission spectrometry -- Part 1: Sampling.	http://www.iso.org/iso/search.htm?qt=15202&sort=rel&type=simple&published=on
CEN EU	15230:2005	Workplace atmospheres. Guidance for sampling of inhalable, thoracic and respirable aerosol fractions.	http://shop.bsigroup.com/ProductDetail/?pid=000000000030133932
NIOSH US	0600	Particles not otherwise regulated, respirable.	Appendix 1 http://www.cdc.gov/niosh/docs/81-123/pdfs/0600.pdf
HSE UK	MDHS 14/3	General methods for sampling and gravimetric analysis of respirable and inhalable dust.	Appendix 2 http://www.hse.gov.uk/pubns/mdhs/pdfs/mdhs14-3.pdf

A review of the different chemical methods to analyse Ni and Ni compounds is out of the scope of this report. However, to facilitate comparison across manufacturing sites and with OELs, it would be desirable for companies to use a standardised analytical method. Table 5 shows a list of methods for Ni analysis from recognised organisations.

All methods are equally suitable for the analysis of Ni and Ni compounds.

Table 5 Guidance document for measuring metals and metalloids

Institution	Standard	Title	Link
ISO	15202-2 and 15202-3	Workplace air- Determination of Metals and Mealloids in Airborne Particulate Matter by ICP- AES. Part: 2 (sample preparation and part 3: analysis).	http://www.iso.org/iso/search.htm? qt=15202&sort=rel&type=simple& ublished=on
CEN EU	BS EN 13890:2009	Workplace exposure. Procedures for measuring metals and metalloids in airborne particles. Requirements and test methods.	http://shop.bsigroup.com/ProductD etail/?pid=000000000030163840
OSHA US	ID-121 ID-125G	Ni and Ni compounds.	http://www.osha.gov/dts/sltc/metho ds/inorganic/id121/id121.html http://www.osha.gov/dts/sltc/metho ds/inorganic/id125g/id125g.html
NIOSH US	NIOSH 9102 NIOSH 7300 NIOSH 7301 NIOSH 7303 NIOSH 6007	Ni and Ni compounds.	http://www.cdc.gov/niosh/docs/200 3-154/
HSE UK	MDHS 42/2	Nickel and inorganic compounds of nickel in air (except nickel carbonyl)	http://www.hse.gov.uk/pubns/mdhs /pdfs/mdhs42-2.pdf

4 SAMPLING STRATEGY

Differences in sampling strategy can be as important as the use of different samplers. Therefore, more comparable data would be obtained when manufacturing sites adopt similar sampling strategies. When developing a sampling strategy it is important to consider the following:

Purpose of the survey: why is the survey being conducted? To collect representative exposure data, to check the effectiveness of control measures, changes in the manufacturing process?

Selection of scenarios and employees: the areas and employees where exposure is likely to occur should be identified and the potential level of contamination categorised (e.g. low, medium, high). Groups of workers with similar exposure (Similarly Exposed Groups – SEGs) should be identified and within each group that require sampling, a small number of employees should be selected for monitoring.

Duration of the sampling period: agreement should be made as to on whether the exposure assessment is intended to represent long-term (representative of an 8-hrs shift) or short-term exposure (usually 15- mins). For long-term exposure we recommend a sampling duration of 6 hours or more. Details on how to derive estimates of short-term exposure from full-shift exposure measurement data are provided in ECHA (2010).

Number of samples for the assessment: recently, the British and Dutch occupational hygiene societies jointly published a sampling strategy guidance for testing compliance with OELs for airborne substances.⁷ This guidance recommends that for each SEG, 3 samples are initially taken. If results are all below 0.1 of the OEL, then no more samples are required. Similarly, if one or more of the samples are above the OEL then no more samples are required as there is sufficient evidence for the need to improve control measures. In other cases when exposures are between 0.1 x OEL and OEL, 6 more samples are collected, including repeated measurements on the same individual, and several statistical tests are carried out to determine compliance. The EU chemical agency (ECHA, 2010) recommends collecting at least 6 samples to represent a single work activity (process) in one company and no less than 12 samples to represent an activity in an industrial sector (note that data for one company is unlikely to represent the entire industrial sector). ECHA has suggested samples sizes considering the risk characterization ratio (RCR) and the uncertainty of the measured levels. The RCR is the margin between the limit value involved (e.g. DNELs/DMELs (derived non-effect level)) and the measured level. Table R.14-2 of the ECHA guidance has been reproduced in Appendix 3.

Other contextual information: exposure controls and personal protection equipment, exposure pattern (continuous, single event, repeated events), description of the workplace and tasks carried out, and any observations that could influence on the concentrations (e.g. variations in the pump flow-rate) should be properly recorded.

Chemical analysis of Ni and Ni compounds: the use of a recognised method for the analysis of Ni is recommended as well as an assessment of the inter-laboratory differences associated with the analysis of Ni. This can help to better understand the

⁷ <http://www.bohs.org/library/technical-publications/>

differences in the concentration measured at different sites. Manufacturing sites could also get involved in existing proficiency laboratory schemes such as Workplace Analysis Scheme for Proficiency (WASP).

Further information on how to develop sampling strategies to evaluate the effectiveness of risk management plans is available in EN 689 (CEN, 1995). The OECD (2003) has issued guidance on how to report sampling information.

5 DICUSSION AND RECOMMENDATIONS

The IOM and cyclone sampling heads are well recognised for following the ACGIH/ISO/CEN curves for inhalable and respirable dust, respectively. Both samplers have been widely studied and their sampling efficiencies are well characterized. The IOM and CIS dual samplers and the Respicon offer the advantage of sampling simultaneously both particle size fractions, allowing direct estimation of the respirable amount of Ni contained in the inhalable fraction. However, fewer studies have assessed the performance of these multi-fraction samplers. The main advantages and drawbacks of the proposed samplers are summarised in Table 6. In addition, the use of foam tends to be associated with a higher LOD due to greater gravimetric instability.

Table 6 Main advantages and disadvantages of inhalable and respirable samplers

	IOM inhalable head	IOM dual head	CIS/GSP	Respicon	Cyclone
Aerosol fractions sampled?	I	I, R	I, R	I, T, R	R
Deviations from the ACGIH/CEN/ISO criteria with variations in flow-rate	N	N	Y	Y	Y
Deviations from the ACGIH/CEN/ISO criteria at low wind speeds ($< 0.24 \text{ m s}^{-1}$)	Y	Y	Y	NA	N
Deviations from the ACGIH/CEN/ISO criteria with large particles ($> 100 \mu\text{m}$)	Y	Y	N	NA	N
Particle deposits in cassette wall	Y	Y	N	N	N
Cost (comparison includes cassettes and sampling mediums)	Low	Low	Low	Expensive	Low (plastic cyclones)

I= Inhalable, R = respirable, T=thoracic

The IOM sampler has been shown to perform well between air velocities of 0.5 and 4 m s^{-1} . At low wind speeds ($\sim < 0.5 \text{ m s}^{-1}$) and in environments with large particles ($> 100 \mu\text{m}$) (Kenny et al. 1997a; Sleet and Vincent, 2011) the IOM sampling head tends to oversample slightly. At high wind speeds ($> 4.0 \text{ m s}^{-1}$) more particles are deposited on the walls of the cassette. Therefore if only the filter is included in the gravimetric analysis (which is not the approved method), the results may be underestimates compared to the actual air concentrations. In contrast, if both cassette and filter are included the sampler may over-read (as particles could be blown directly into the sampler). However, wind velocities of 4 m s^{-1} are uncommon in most occupational scenarios; most working environments with standard air exchange rates generally have wind velocities below 0.3 m s^{-1} (Baldwin and Maynard, 1998).

The IOM sampling efficiency increases with large particles ($> 100 \mu\text{m}$) as these tend to be captured into the IOM inlet as projectiles due to their inertia, since the aperture of the inlet is 15 mm. However, it should be noted that the inhalable fraction is undefined in this size range so this may not be problematic. In addition, this should not be a problem in the Ni industry as previous studies in a Ni refinery have shown MMAD of approximately 10-15 μm (Kerr et al. 2001; Creely and Aitken, 2007), up to $\sim 60 \mu\text{m}$ (Yu et al., 2001).

The IOM cassette has to be weighed together with the filter as a single unit, since particles may deposit in the walls of the cassette. Thus, for the analysis of Ni the inside of the cassettes must be washed with the extractant solvent so all deposits are included in the analysis. A clearly advantage of the IOM sampler is that changes in the flow-rate (up to 10.6 l. min^{-1}) do not result in deviations from the inhalability criteria, except for large particles ($> 80 \mu\text{m}$) (Zhou and Chen, 2010). Deviations of the flow-rate are likely to occur during personal sampling as the tubing connecting the sampler with the pump bends/kinks as the employee carries out work.

The cyclones perform well as long as the flow-rate is stable (Görner et al., 2001) but their performance does change markedly with changes in flow-rate.

The CIS has been studied mostly for collection of the inhalable fraction, without the foam inserts. Sleet and Vincent (2011) reported lower concentrations collected with the CIS than with the IOM head for the inhalable fraction in a laboratory study. In contrast, the multi-fraction sampler (used with the foams) was reported to collect higher concentrations of inhalable and respirable manganese when compared to the IOM head and HD cyclone, respectively (IOM, unpublished study). In addition blank PUF showed a higher and more variable Mn content than the filters used with the IOM and cyclone heads.

A major drawback of the use of foams is that they have higher gravimetric instability compare to filters, requiring longer equilibration periods and rigidly controlled temperature and relative humidity environments. In addition, as the inhalable fraction is the sum of the foams and filter insert the inaccuracies of both sampling mediums have to be taken into account leading to higher LODs than those present when only one filter is needed.

The PUF used with the CIS sampler has been reported to be easily digested in HNO_3 , without releasing any visible particle (IOM, unpublished study), similarly to what had been previously reported when researching foams as separating particle mediums started (Möhlmann et al. 2002). In Möhlmann's study Ni levels in PUF were up to $25 \mu\text{g Ni g}^{-1}$ foam (approximately $6.25 \mu\text{g Ni}$ per foam for a 0.25 g foam). As it is not clear if this varies between batches of foams it was recommended that this should be re-assessed for each package of foams. The performance of PUF in other extractants that may be required for Ni speciation studies have not been documented in the peer-review literature.

The Respicon and IOM sampler were compared for collection of Ni dust in a Ni refinery as part of the CALTOOL programme (the program consisted of development of a protocol to compare inhalable sampling devices in field environments). Results showed that the Respicon under-sampled the inhalable fraction compared to the IOM head (Koch et al. 2002). The authors acknowledged that results can be corrected with a factor based on the extrathoracic fraction. As explained for the CIS, the calculation of

the inhalation fraction involves adding the mass collected on the three filters, which results in higher LODs compared to samplers that use a single sampling medium.



Since separation of particles in the Respicon depends on the flow-rate, deviations from the nominal flow-rate can lead to sampling errors on the mass of particles collected in each fraction, whereas for the IOM head, changes in the flow-rate do not result in significant errors in the sampling efficiency as size fractioning is achieved through the design of the sampler's head. However, sampling of large aerosols has been associated with increase sampling efficiencies in the IOM head.

For the selection of the sampler material, plastic or metal, the temperatures in the environment where the survey will be carried out should be considered. Plastic samplers are a less expensive choice. However, in areas with very high temperatures (e.g. tapping of molten metals) the sampler could be damaged and a stainless steel sampler would be preferred.

Introducing the same sampling methods may not be feasible as companies and sites will also have to conform to national requirements. However, the use of the same method would ensure that there is a level of consistency between companies and sites when comparing exposure levels to international occupational exposure standards. Therefore, although companies have to use their national methods it would be desirable to carry out an annual survey using the same method.

For routine measurement of personal inhalable and respirable exposures to Ni, the IOM and CIS inhalable and the cyclone samplers (HD or OD) are likely to provide more accurate personal exposure data for the different fractions at a lower cost. For similar cost, the use of these samplers is preferred over the use of a single multi-fraction sampler such as the CIS and the IOM dual fraction sampler because of the possibility of high background levels of Ni in the foams, the lower gravimetric stability of the foams and lower ease of its use. Whereas CIs provide data on the full PSD the analysis of multiple filters results in higher costs, data analysis is more complex and may require longer measurement durations in order to be able to collect detectable levels on each stage of the impactor.

6 REPORT AUTHOR AND APPROVER'S SIGNATURE

<p>Report prepared by:</p>  <p>..... Dr. Araceli Sánchez Jiménez Research Scientist IOM Consulting Ltd.</p>	<p>Authorised by:</p>  <p>..... Dr Martie van Tongeren Section Head Exposure Assessment IOM Consulting Ltd.</p>
--	---

7 REFERENCES

ACGIH. 1998. Particle Size-Selective Sampling for Particulate Air Contaminants. Cincinnati, OH: American Conference of Government Industrial Hygienists.

Möhlmann C , Aitken RJ, Görner P, Kenny LC, Duc vu Trinh, Zambeli, G (2002). Size Selective Personal Sampling Using Porous Plastic Foams. BIA

Aitken RJ, Donaldson R. (1996). Large particle and wall deposition effects in inhalable samplers. Sudbury: HSE Books. HSE Contract Research Report No. 117/1996.

Aizenberg V, Choe K, Grinshpun SA. (2001). Evaluation of personal aerosol samplers challenged with large particles. *Journal of Aerosol Science*; 32: 779-793.

Baldwin PEJ, Maynard AD (1998) A survey of wind speeds in indoor workplaces. *Annals of Occupational Hygiene*; 42:303-313

CEN (1993) Size Fraction Definition for Measurement of Airborne Particles, European Standard EN 481: CEN European Committee for Standardization, rue de Stassart 36, B-1050 Brussels, Belgium.

CEN 1995. Workplace atmospheres – Guidance for the assessment of exposure by inhalation to chemical agents for comparison with limit values and measurement strategy. CEN 689. European Committee for Standardization (CEN), Brussels.

Creely KS, Aitken RJ (2007) Characterisation of nickel industry workplace aerosols by particle size and nickel species. IOM Research Report TM/07/03, Edinburgh, UK.

Demange M, Gorner P, Elcabache J-M., Wrobel R. (2002). Field comparison of 37-mm closed face cassettes and IOM samplers. *Applied Occupational and Environmental Hygiene*; 17: 200–208.

ECHA (2010) Guidance on information requirements and chemical safety assessment. Cahpeter R.14: Occupational exposure estimation. European Chemical Agency, Finland.

Görner P, Wrobel R, Micka V, Skoda V, Denis J, Fabries J. (2001). Study of fifteen respirable aerosol samplers used in occupational hygiene. *Annals of Occupational Hygiene*; 45: 43-54.

Görner P , Xavier S, Wrobel R, Kauffer E, Witschger O. (2010) Laboratory Study of Selected Personal Inhalable Aerosol Samplers. *Annals of Occupational Hygiene*;54: 165–187

HSE (2000). MDHS 14/3 General methods for sampling and gravimetric analysis of respirable and inhalable dust, Methods for the determination of hazard substances. HSE Books, London.

Kenny LC, Aitken RJ, Baldwin PEJ, Beaumont GC, Maynard AD. (1999). The sampling efficiency of personal inhalable aerosol samplers in very low air movements. *Journal of Aerosol Science*; 30: 627-638.

Kenny LC, Aitken R, Chalmers C, Fabries JF, Gonzalez-Fernandez E, Kromhout H, Liden G, Mark D, Riediger G, Prodi V. (1997a). A collaborative European study of personal inhalable aerosol sampler performance. *Annals of Occupational Hygiene*; 41: 135-153.

Kenny LC, Stancliffe JD. (1997b). Characterisation of porous foam size selectors for the conical inhalable sampler. Available from URL: <http://www.bgiusa.com/ih/cisisfmpdf.pdf>.

Kerr SM, Vicent JH, Ramachandran G (2001) A New Approach to Sampling for Particle Size and Chemical Species 'Fingerprinting' of Workplace Aerosols. *Annals of Occupational Hygiene*; 45: 555-568

Lidén G, Harper N. (2007) *Journal of Occupational and Environmental Hygiene*. *Journal of Occupational and Environmental Hygiene*; 3: D94–D101

Lidén G, Melin B, Lidblom A, Lindberg K, Noren JO. (2000). Personal sampling in parallel with open-face filter cassettes and IOM samplers for inhalable dust—Implications for occupational exposure limits. *Applied Occupational and Environmental Hygiene*; 15: 263–276.

Möhlmann C, Aitken RJ, Kenny LC, Görner P, Vu Duc T, Zambelli G. (2002) Porous Foam Aerosol Sampling (PoFAS), Berufsgenossenschaftliches Institut für Arbeitssicherheit – BIA

Ogden TL, Birkett JL. The Human Head as a Dust Sampler. In: *Inhaled Particles IV*, W.H. Walton, ed., pp. 93–105. Pergamon Press, Oxford, UK (1997).

OECD 2003. Guidance document on reporting summary information on environmental, occupational and consumer exposure. OECD Environment, Health and Safety Publications, Series on Testing and Assessment No. 42. ENV/JM/MONO(2003)16. Available online at [http://www.oecd.org/officialdocuments/displaydocumentpdf/?cote=env/jm/mono\(2003\)16&doclanguage=en](http://www.oecd.org/officialdocuments/displaydocumentpdf/?cote=env/jm/mono(2003)16&doclanguage=en) Last accessed 12th Jan 2012

Sánchez Jiménez A, Galea KS, M, Aitken RJ. (2010) Guidance for collection of relevant particle size distribution data of workplace aerosols-Cascade Impactor Measurements. IOM Research Report TM/09/04, Edinburgh, UK.

SCOEL (2010). Recommendation From the Scientific Committee on Occupational Exposure Limits for Nickel and Inorganic Nickel Compounds SCOEL/SUM/85. June 2011.

Sleet DK, Vincent JH (2011) Performance Study of Personal Inhalable Aerosol Samplers at Ultra-Low Wind Speeds. *Annals of Occupational Hygiene*: 1–14

Teikari M, Linnainmaa M, Laitinen J, Kalliokoski P, Vincent J, Tiitta P, Raunemaa T. (2003). Laboratory and field testing of particle size-selective sampling methods for mineral dusts. *American Industrial Hygiene Association Journal*; 64: 312 – 318.

Trakumas S, Hall P (2003) Performance assessment of personal respirable cyclone samplers. AIHce presentation 191.

Tsai PJ, Vincent JH, Wahl G, Maldonado G (1995). Occupational exposure to inhalable aerosol in the primary nickel production industry. *Occupational and Environmental Medicine*; 52:793-795.

Tsai PJ, Werner MA, Vincent JH, Maldonado G (1996a). Exposure to nickel-containing aerosols in two electroplating shops: Comparison between inhalable and 'total' aerosol. *Applied Occupational and Environmental Hygiene*; 11:484-492.

Tsai PJ, Vincent JH, Wahl GA, Maldonado G (1996b). Worker exposure to inhalable and 'total' aerosol during nickel alloy production. *Annals of Occupational Hygiene*; 40:651-669.

Vaughan NP, Chalmers CP, Botham, RA. (1990). Field comparison of personal sampler for inhalable dust. *Annals of Occupational Hygiene*; 34: 553-573.

Vincent JH. *Aerosol Sampling: Science, Standards, Instrumentation and Applications* John Willey, West Sussex, 2007

Vincent JH, Tsai PJ, Warner JS (1995). Sampling of inhalable, thoracic, and respirable dust fractions with application to speciation. *The Analyst*; 120:675-679.

Vincent PS, Thomassen Y, Hetland S. (1995). A method for establishing tentative occupational exposure limits for inhalable dust. *Annals of Occupational Hygiene*; 39: 795-800.

Wilsey PW, Vincent JH, Bishop MJ, Brosseau Lm, Greaves IA. (1996). Exposures to inhalable and 'total' oil mist aerosol by metal machining shop workers. *American Industrial Hygiene Association Journal*; 57: 1149-1153

Zhou Y and Chen YS (2010) Evaluation of IOM Personal Sampler at Different Flow Rates *Journal of Occupational and Environmental Hygiene*; 7: 88-93

Wu YH, Vincent JH. (2007) A Modified Marple-Type Cascade Impactor for Assessing Aerosol Particle Size Distributions in workplaces. *Journal of Occupational and Environmental Hygiene*; 4: 798-807.

Yu CP, Hsieh TH, Oller AR, Oberdörster G. (2001) Evaluation of the human nickel retention model with workplace data. *Regulatory Toxicology and Pharmacology*; 33:165-72.

APPENDIX 1 NIOSH METHOD 0600 PARTICULATES NOT OTHERWISE REGULATED, RESPIRABLE

[NIOSH 0600.pdf](#)

APPENDIX 2 MDHS 14/3 GENERAL METHODS FOR SAMPLING AND GRAVIMETRIC ANALYSIS OF RESPIRABLE AND INHALABLE DUST

[MDHS_14_3.pdf](#)

APPENDIX 3 ECHA INDICATIVE NUMBER OF MEASUREMENTS NEEDED

Table R.14-2: Indicative number of measurements needed to determine confidently that the true RCR is below 1

		RCR : <1 - 0.5	RCR : <0.5 - 0.1	RCR : <0.1
		N	N	N
Variation and uncertainty in the data ⁵	Low [^]	~20-30	12-20	6-12
	Moderate +	~30-50	~20-30	12-20
	High*	>50	~30-50	~20-30

N= number of samples

RCR = Risk Characterisation Ratio

⁵ Variation and/or uncertainty can be caused by on the one hand true variation in exposure (as indicated by a measure of variation) and on the other hand by lack of knowledge about how representative the data are for the situation to be assessed.

* **High:** a high geometric standard deviation (GSD) in the measured data (e.g. > 3.5) or the representativeness of the data is suspected to be significantly uncertain for the situation to be assessed.

+ **Moderate:** a moderate GSD (e.g. 2 – 3.5) and/or the representativeness of the data is questionable.

[^] **Low :** a low GSD (e.g. < 2) and the data can be considered representative for the situation to be assessed.